



Understanding Bearing Reliability in Permanent Magnet Generators

Dr John Coultate
R&D and Consulting Dept. Leader
Romax Technology

Commercially Confidential

Contents

Understanding Bearing Reliability in Permanent Magnet Generators

- Consortium partners
- Direct drive wind turbines – key issues
- Project aims; major project milestones

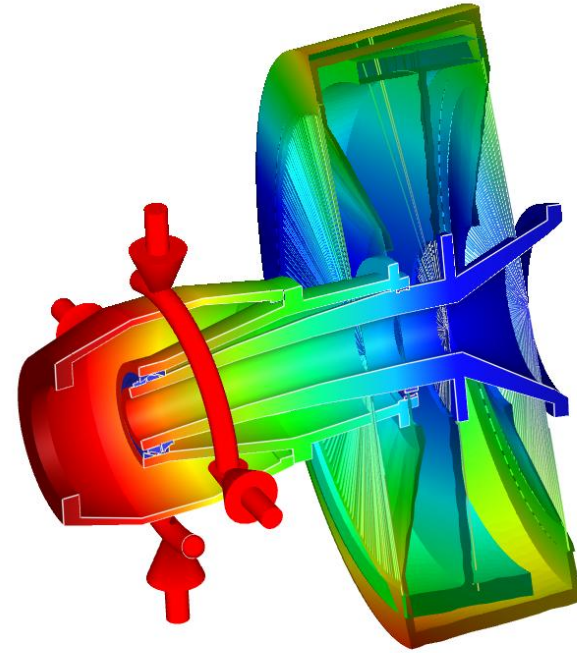

Romax Are...

Rotating Machinery Experts...



Romax Wind Turbine Experience

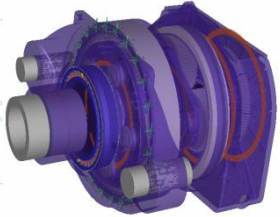

Gearbox Design

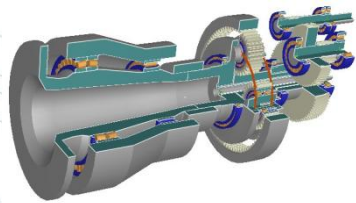

Drivetrain Design

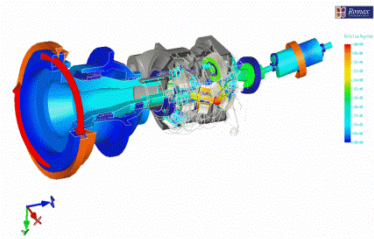

Drivetrain Dynamics

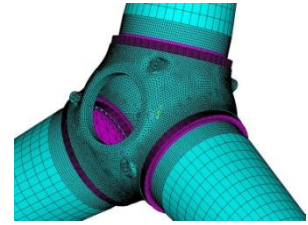

Large Bearings



Manufacturing & Certification



Drivetrain Concept Layout



“Innovative” Research



Test Specification & Test Design



Measurement



Field Support

Romax Technology – Over 20 Years in the Field

**ROMAX
DESIGNER
RELEASED
1995**

**DTI SMART
AWARD
1998**

**10 OFFICES WORLDWIDE SERVING
WIND TURBINE, AUTOMOTIVE
AEROSPACE, HEAVY INDUSTRIES, MARINE, RAIL**

**DELOITTE
FAST 50
2003 & 2004**



**QUEENS
AWARD
2004**



**QUEENS
AWARD
2009**

**ESTABLISHED
WITH NIST
SEED FUNDING
1989**



2008

The University of Sheffield – Electrical Machines and Drives Group

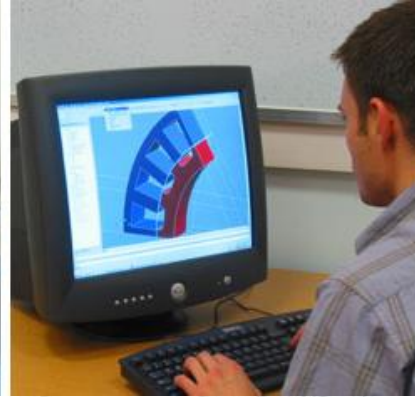

- Fundamental and applied research on enabling technologies in electrical power engineering
- Areas or expertise include:
 - Magnetics
 - Electrical machines - motors/generators/actuators
 - Novel machine topologies
 - Noise and Vibration
 - Power Electronics
 - Control Systems
 - Demonstrator Prototyping/Testing

Direct Drive Wind Turbines

Direct Drive Wind Turbines

- This project focuses on direct drive and medium-speed wind turbine generators
- Direct drive turbines have no gearbox – no gears and fewer bearings in an effort to increase reliability
- However, a range of issues affect direct-drive turbine reliability:
 - Generator component failure – windings; laminations; etc.
 - Failure of complex power electronics
 - **Failure of generator bearings**

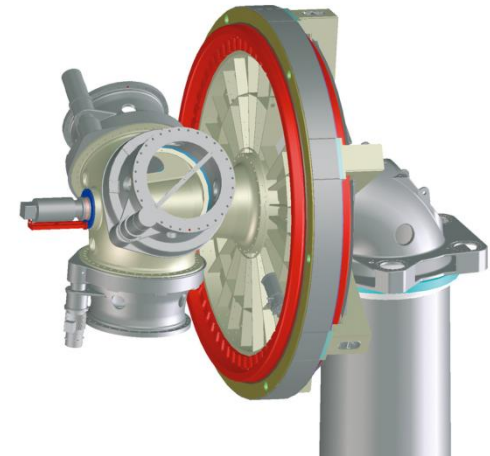

Direct Drive Wind Turbines

- Interactions between magnetic loads in the generator, wind turbine loads and bearing reliability is currently not understood
- This project aims to:
 - 1) Increase our understanding of bearing operating conditions
 - 2) Increase our understanding of generator and drivetrain dynamics
 - 3) Improve design tools for direct drive wind turbines to de-risk future offshore wind farms

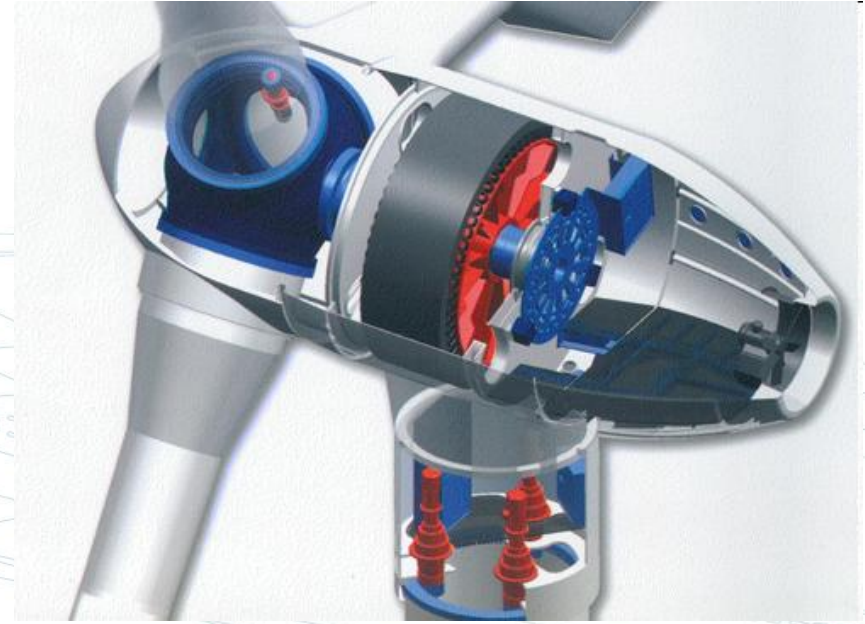

Direct Drive Wind Turbines

- Direct-drive wind turbine case study in RomaxWind software:

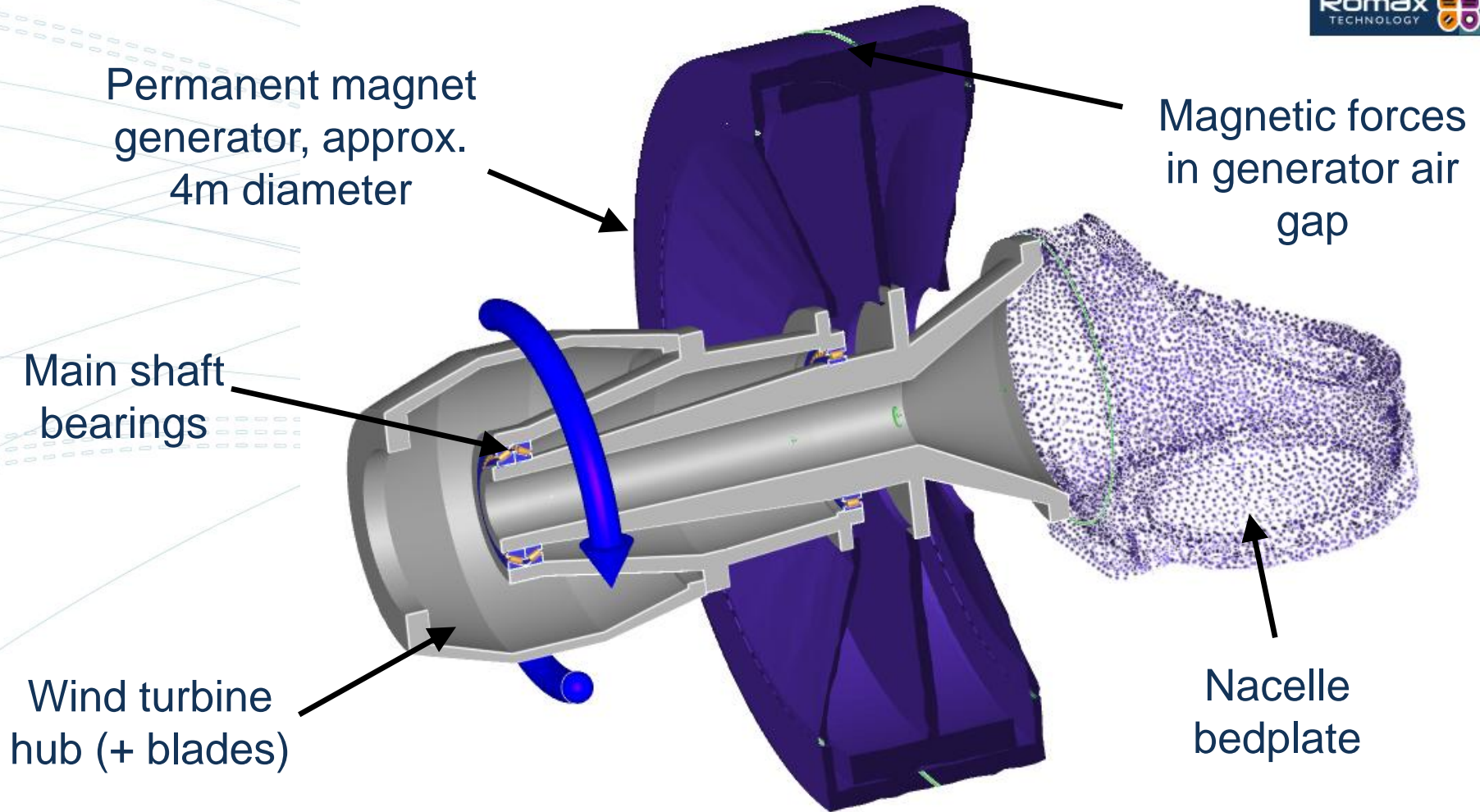

Direct Drive Wind Turbines

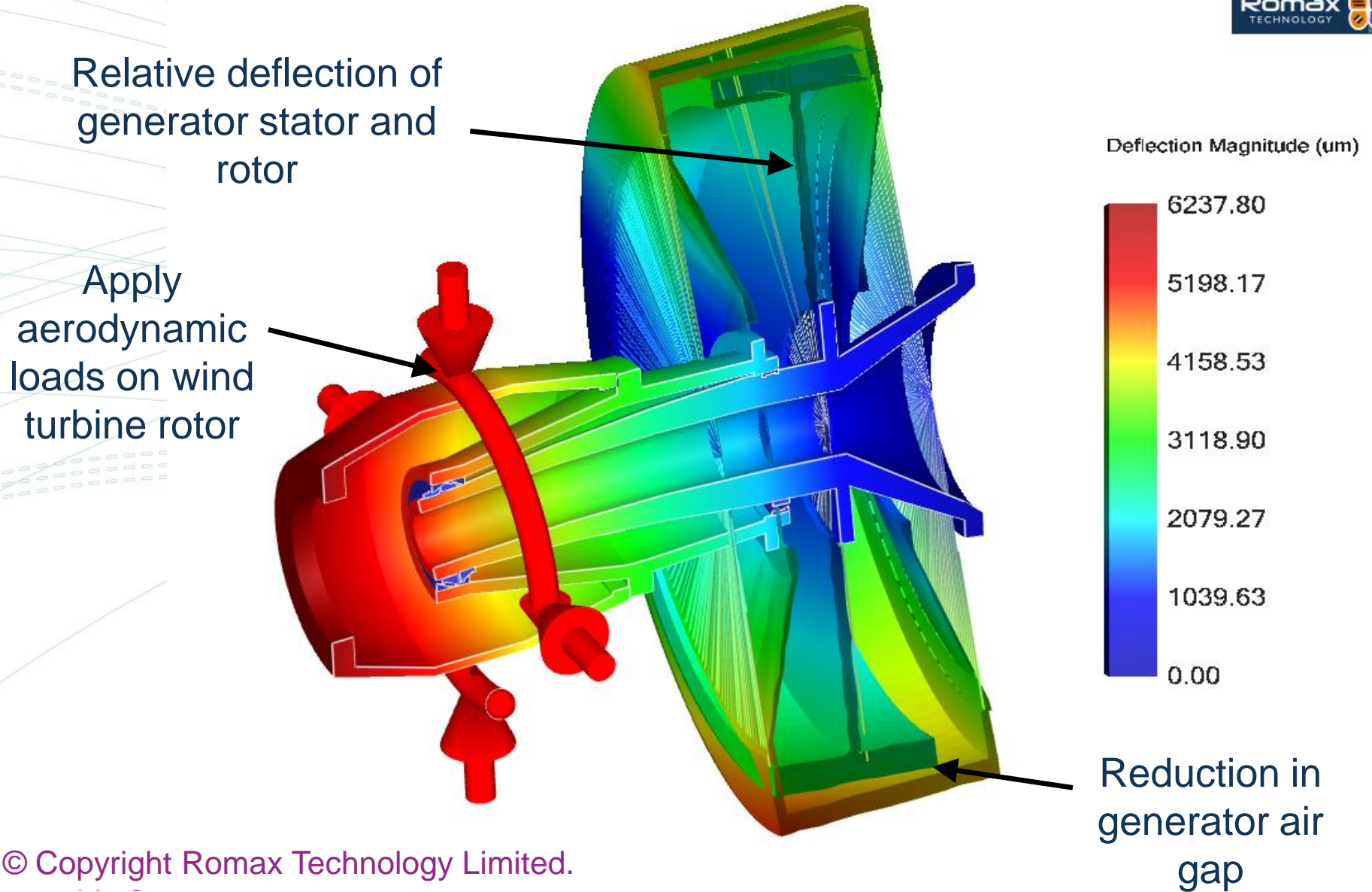

Direct Drive Wind Turbine – Load Case Analysis

- Bearing stresses and lives are predicted under wind turbine aerodynamic loading:

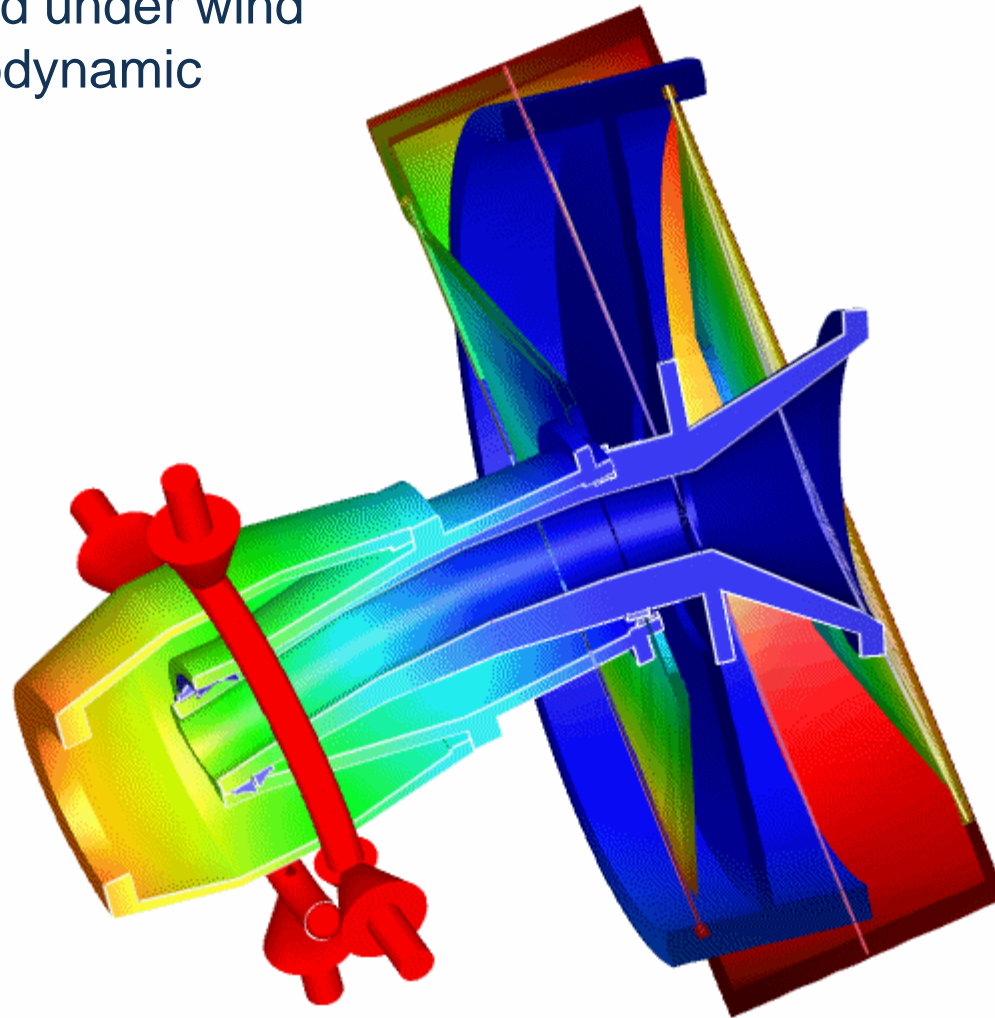

Deflection Magnitude (um)

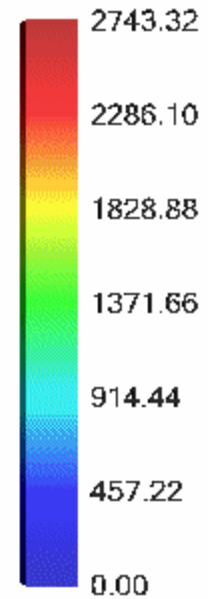

Key Project Milestones

Key Project Milestones

(2) Model validation

- Small-scale generator test rig at The University of Sheffield will validate all simulations and modelling methods
- Models are extrapolated from small-scale tests to full-size wind turbine case studies

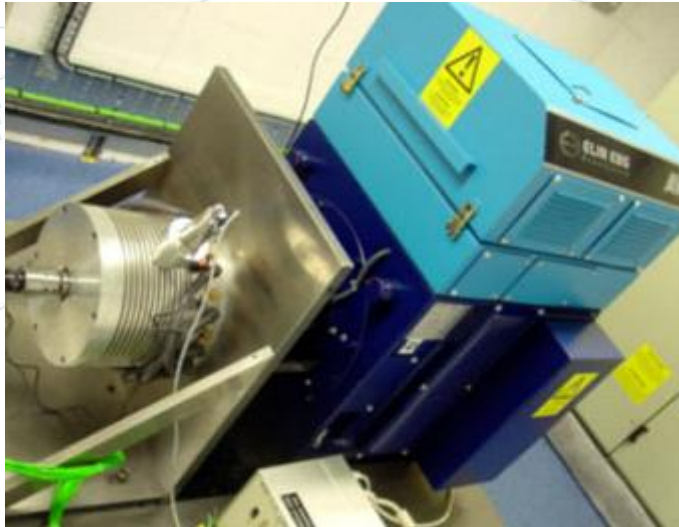

Summary

Summary

- Main outcomes of this project will be:
 - 1) A better understanding of wind turbine generator behaviour and factors affecting bearing reliability
 - 2) De-risking the design processes for direct drive wind turbines
 - 3) The ultimate aim is improved reliability of offshore wind turbines = reduced cost of electricity





UK Head Office

T: +44 (0)115 951 8800

E: sales@romaxtech.com

Japan

T: +81 (0) 3 3716 9249

E: sales_jp@romaxtech.com

Europe

T: +33 (0) 6 80 91 82 80

E: sales_eu@romaxtech.com

South Korea

T: +82 (0) 70 7580 6210

E: sales_kr@romaxtech.com

China

T: +86 571 8378 6230

E: romaxchina@romaxtech.com

North America

T: +1 (0) 248 250 7691

E: sales_us@romaxtech.com

India

T: +91 (020) 6560 2288

E: sales_in@romaxtech.com

Romax Technology Limited is a leading independent drivetrain consultancy offering technical consulting, design services and software tools for gearboxes, drivetrains and bearings for the transportation and wind energy industries.

Romax offers both its consultancy services and its software package, RomaxDesigner, to grant clients confidence in all aspects of drivetrain design, analysis and dynamics.



www.romaxtech.com